

SAMPLE

Licensed Electricians Practical Assessment (LEP) 2019

Surname: _____

Date: _____

Given Names: _____

Time: _____

Assessment Time (includes 10 minutes reading time): 4 hours
At the end of this time you will be asked to stop.

Have you undertaken an LEP tutorial (refresher training)?

(Please circle one)

YES

NO

Candidates Signature: _____

Assessors Name: _____

Assessors Signature: _____
 (to be signed when candidates identification is confirmed)

Marks Allocation										Possible	Actual
Question 1	Meter Panel and Switchboard Wiring									35	
Question 2	Electrical Installation Testing	2.1	2.2	2.3	2.4	2.5	2.6	2.7	2.8	32	
Question 3	MEN System Voltage Measurement	3.1				3.2				18	
Question 4	Visual Defects									15	
Total										100	

This LEP assessment will comprise four (4) questions. Throughout the assessment, the LEP assessor will instruct you as to which workstation to use and when to move to them.

- Q1.** Meter Panel and Switchboard Wiring
- Q2.** Electrical Installation Testing
- Q3.** MEN System Voltage Measurements
- Q4.** Visual Defects

The following documents may be referred to during this assessment:

1. AS/NZS 3000:2018 Wiring Rules incorporating all amendments
2. AS/NZS 3017:2007 Electrical installations – Verification guidelines
3. AS/NZS 3008.1.1:2017 Electrical installations – Selection of cables
4. The Victorian Service and Installation Rules 2014

SAMPLE

Question 1

Wiring Bay Number

Meter Panel and Switchboard Wiring

A mark will be deducted for each missing or incorrect unit where required

You are required to install a 3Φ 4 wire 400/230V 50Hz air conditioned business premises. The installation comprises a 3Φ meter panel and main switchboard in a common enclosure, and a separate 1Φ distribution board. The main switchboard and the distribution board are situated in the same building.

The installation is located at 37 City Road, Jonesville.

The installation will be supplied from:

- Overhead supply** – from the fused overhead line connector box to the main switchboard. The consumers mains are V90 SDI stranded copper cables. The cables are run enclosed in air.
- Underground supply** – from the service pit, the cables run underground in PVC conduit at a depth of 500mm. The consumers mains are V90 SDI stranded copper cables.

The meter panel enclosure is located on the front of the building, 4 meters from the southern property boundary, and 3 metres from the western property boundary. The underground pit is located at the south west corner of the property.

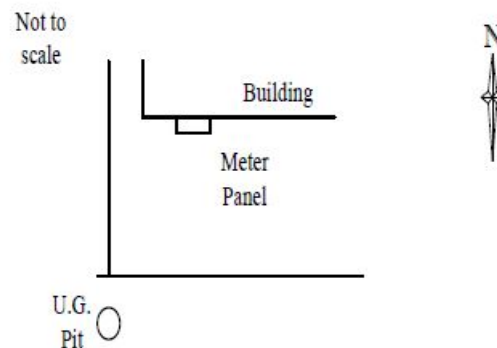

All wiring and identification is to be carried and completed to the requirements of AS/NZS3000:2018 Wiring Rules. You may ignore voltage drop requirements. Assume unity power factor on all loads. All cables installed are solid/stranded and will operate at normal operating temperatures.

You must select and arrange main switches, circuit breakers, RCDs and cables from the equipment provided. Divide the equipment in the installation into final sub-circuits, as per AS/NZS3000:2018 requirements. Select the **minimum** permissible cable size (cables available for final sub-circuits are 1.5mm², 2.5mm², 4mm² and 6mm²) and correct circuit protective device rating for each circuit.

Do not cut any cables or bus-bar, or take any equipment from another workstation, unless directed by your assessor. Inform your assessor if there is any equipment missing or not provided.

Note: Although Appendix C of AS/NZS3000:2018 Wiring Rules is classed as informative (i.e. for guidance only), Appendix C Tables C1, C2, C5 and C9 may be used in this assessment where appropriate.

Note: AS/NZS3008.1.1 shall be used for all cable selection and cable current ratings.

The installation will comprise of the following:

Equipment installed from the main switchboard:

- 1 - 3Φ 24A reverse cycle air conditioner, 230V control, wired to an external enclosure. The manufacturers instructions state the air conditioner must have RCD protection.
- 1 - 1Φ 4.7kW range
- 42 - 230V 16W LED luminaires, installed over two circuits. Both circuits are to be installed on the same phase.
- 1 - 230V 3.8kW electric vehicle charger

Equipment installed from the distribution board:

An isolating device is required to be fitted at the distribution board to control all loads.

- 16 – 230V 10A double socket outlets installed over two circuits,
- 40 - 230V 16W LED luminaires on one circuit

Note: Use of RCDs and/or RCBOs permitted

The 3Φ final sub-circuit wiring is V90 single insulated cable, installed enclosed in the cable duct/conduit provided.

The 1Φ sub-main is V90 single insulated cable, installed enclosed in the cable duct/conduit provided.

All 1Φ final sub-circuit wiring in the installation is two core and earth V90 flat copper TPS, installed partially surrounded in thermal insulation.

Note: This installation will never be connected to the electrical supply. Some parts and equipment may not satisfy the requirements of AS/NZS3000:2018 and other associated standards, they are only used in the assessment environment to keep assessment costs to a minimum. Please ask your assessor if you have any questions in relation to this.

Calculate the maximum demand of the installation. Use the maximum demand table below for your working.

Maximum Demand Table Used _____

Equipment 3Φ Main Board	Load Group	Calculations	Red	White	Blue
1 - 3Φ 24A reverse cycle air conditioner					
1 - 1Φ 4.7kW range					
42 - 230V 16W LED luminaires all on the same phase					
1 - 230V 3.8kW electric vehicle charger					
Equipment 1Φ Distribution Board					
16 - 230V 10A double socket outlets					
40 - 230V 16W LED luminaires					
Totals					

Based on the maximum demand calculation, select the current rating of the main switch, the **minimum** size of the consumers mains cable, and the **minimum** size of the main earth conductor.

Based on the maximum demand calculation, select the current rating of the distribution board isolator, and the **minimum** size of the sub-main cable.

Enter these details into the table below, and state the AS/NZS 3008.1.1 Table number and column number used for your cable selection

Consumers Mains: Table..... Column

Sub-main: Table..... Column

Three phase load: Table..... Column

Single phase loads: Table..... Column

Maximum Demand of the Installation	Current Rating of the Main Switch	Size of the Consumers Mains Cable	Size of the Main Earth Conductor

Maximum Demand of the Distribution Board	Current Rating of the Distribution Board Sub-main Circuit Protection	Size of the Sub-Main Cable

Question 1 = 35 marks

Question 2

Electrical Installation Testing **Bay Number**

A mark will be deducted for each missing or incorrect unit where required

Using your insulation resistance and continuity tester, carry out the following tests, as required under AS/NZS3000:2018, on the electrical installation indicated by the assessor.

NEUTRAL CONDUCTORS MUST NOT BE DISCONNECTED

Insert the meter readings with the correct units, and other information as required, in the appropriate places throughout question 2.

2.1 Resistance of Main Earth and Bonding Conductors

Test	Record Instrument Reading & Units	Indicate if Test is Pass or Fail
Main Earthing Conductor		
Bonding conductor to water pipe		

(1+ 1 = 2 marks)

2.2 Insulation Resistance of Wiring

Circuit Test	Record Instrument Reading & Units	Indicate if Test is Pass or Fail
Whole Installation (wiring only)		
Final sub-circuit 1		
Final sub-circuit 2		
Final sub-circuit 3		
Final sub-circuit 4		

(5 x 2 = 10 Marks)

2.3 Earthing and Insulation Resistance of Appliance

Test	Record Instrument Reading & Units	Indicate if Test is Pass or Fail
Earthing of Exposed Metal		
Insulation Resistance		

(1 + 2 = 3 marks)

2.4 Resistance of Protective Earthing Conductors

Determine Pass or Fail using Table 8.2 of AS/NZS3000:2018 Wiring Rules

Test	Active Cond. Size mm^2	Earth Cond. Size mm^2	Protective Device Rating Type C	Active Cond. Resistance (R_{ph}) (Given)	R_e Value & Units (Measured)	R_{phe} Value & Unit (Calculated)	Indicate if Test is Pass or Fail
Ceiling Rose	1.5 mm^2	1.5 mm^2	10A	0.90 Ω			
Fluorescent	1.5 mm^2	1.5 mm^2	10A	0.50 Ω			
Socket Outlet 1	2.5 mm^2	2.5 mm^2	16A	0.25 Ω			
Socket Outlet 2	2.5 mm^2	2.5 mm^2	20A	0.40 Ω			

(4 x 1 = 4 marks)

2.5 Polarity Test of Consumer's Mains

Test	Record Instrument Reading & Units	Indicate if Test is Pass or Fail
Consumer's Mains Active		
Consumer's Mains Neutral		

(1 +1 = 2 marks)

2.6 Operation of Switches

Switch Under Test	Indicate which conductor is being switched ACTIVE/NEUTRAL/NEITHER	Indicate if Test is a Pass or Fail
Ceiling Rose		
Fluorescent Light		
Socket Outlet 1		
Socket Outlet 2		
Fan Socket Outlet		

(5 x 1 = 5 marks)

2.7 Testing of Circuit for Automatic Disconnection of Supply

Measure the fault loop impedance of the final subcircuit supplying the socket outlet listed in the table below.

The final subcircuits are protected by Type C miniature circuit breakers. The nominal supply voltage of the electrical installation is 230 volts.

Complete the table below, and determine Pass or Fail using Table 8.2 of AS/NZS3000:2018 Wiring Rules

Test Point	Conductor Size		Type C Circuit Breaker Rating	Measured Value & Units	Value of R_{dhe} & Units From T8.2	Indicate if Test is a Pass or Fail
	Active mm^2	Earth mm^2				
Appliance socket outlet	2.5 mm^2	2.5 mm^2				

(2 marks)

2.8 Testing of Operation of RCDs

Using the RCD tester provided, test the three (3) RCD's and record their trip time and trip current at zero degrees.

RCD Under Test	Earth Leakage	
	Trip Time	Trip Current
	Value & Units	Value & Units
1		
2		
3		

(1 + 1 + 1) = 3 marks

You are installing a new circuit to supply a 32A socket outlet in a commercial installation. Are you required to install an RCD on this circuit?

Answer: _____

Wiring Rules Clause Number: _____

1 mark

(3+1=4 marks)

Question 3

MEN System Voltage Measurements

A mark will be deducted for each missing or incorrect unit where required

The equipment on this test panel consists of:

- The earth electrode from the 400/230V distribution system substation MEN star point.
- A single phase electrical installation with earth electrode and bonding to a metallic underground water pipe.

Using the instrument provided, carry out the following tests. On the simulated MEN electrical installation, you are required to take voltage measurements, as follows:

3.1

- With the main switch “ON” and all circuit breakers in the “OFF” position, take a voltage measurement across the terminals of the point of supply.
- Measure the voltage between the
 - independent earth and frame of the appliance (refrigerator)
 - independent earth and water tap/pipe
 - appliance terminals

in each of the switchboard conditions outlined in the table below.

Record the voltage readings and units, and write them in the table below.

The main switch is to be in the “ON” position in all cases

Measure and record the supply voltage at the point of supply (Main switch on, all circuit breakers off)				_____ Volts		
Test Condition	Circuit Breaker 1	Circuit Breaker 2	Circuit Breaker 3	Independent Earth and Appliance Frame (refrigerator)	Independent Earth and Water Tap/Pipe	Appliance Terminals (refrigerator)
1	ON	Off	Off			
2	ON	ON	Off			
3	ON	ON	ON			

(2+2+2+2 = 8 marks)

3.2

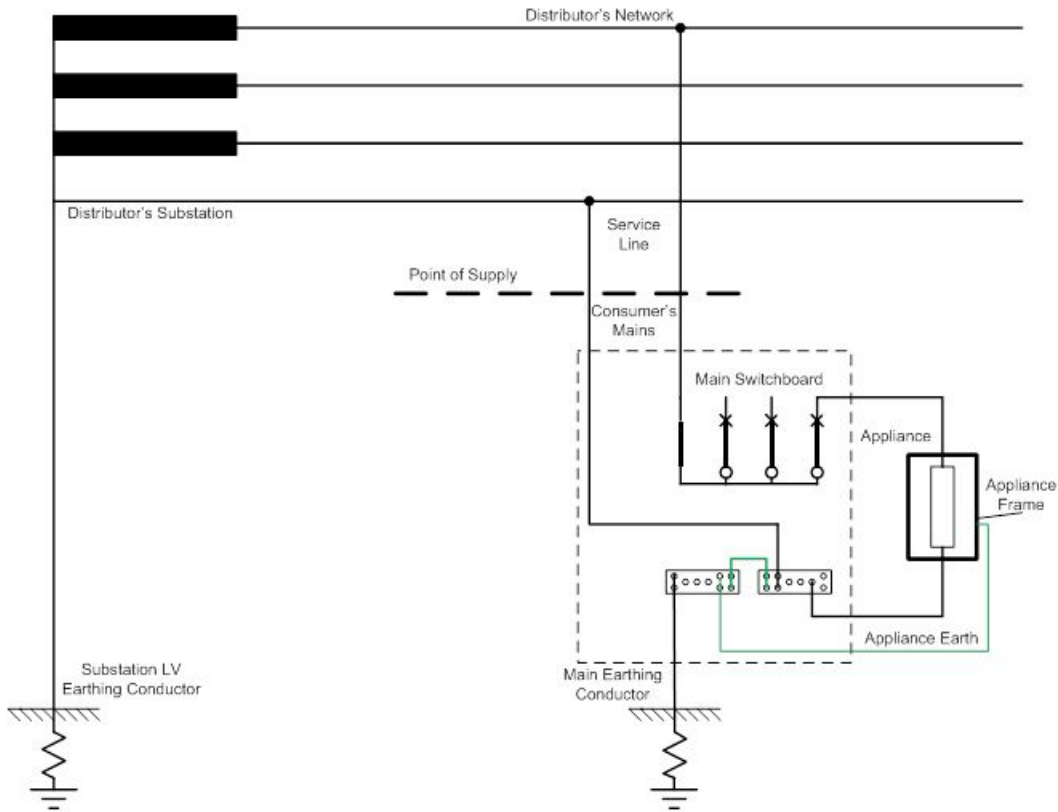

Write a detailed description to explain your voltmeter readings obtained in Question 3.1. You **must** use the diagram provided to show the path of current flow, and identify on the diagram the location of any fault.

.....

.....

.....

.....

.....

.....

.....

.....

.....

.....

.....

.....

.....

.....

.....

.....

.....

.....

.....

.....

.....

.....

.....

.....

.....

.....

.....

.....

.....

.....

.....

SAMPLE

10 Marks

Question 4

Visual Defects

When instructed by the assessor, carry out a visual inspection of the installation.

Your workstation/s to inspect are:

You are to find five (5) installation defects and record them in the table below. **A maximum of three (3) defects may be taken from the switchboard enclosure.**

- Record five **different** instances of non-compliance with the Wiring Rules AS/NZS3000:2018
- Record the defect in the column provided (1 mark)
- Record the complete Wiring Rules Clause (2 marks)
- Indicate the switch or socket outlet number and panel location when recording the defect
- Only the first five recorded defects will be marked

Panel Location	Wiring Defect	Wiring Rules Clause Number

[5 x (1 + 2) =15 marks]